

# Installation Instructions

## PH15 15-Ton Pintle Hook

### Capacity

6,000 lbs. Maximum vertical load

30,000 lbs. Maximum gross trailer weight

#### **WARNING**

Maintain adequate vertical (tongue) load to properly control the trailer (generally 10%) but do not exceed the above rated capacities.

### Towing Applications

Trailers and equipment designed for over-the-road towing within the stated capacities. For off-road applications, reduce the capacities listed above by 25% and use in conjunction with a swivel-type drawbar.

### Drawbar Eye Dimension

2" to 3" I.D. with 1-1/4" to 1-5/8" diameter section

### Mounting

1. Use a secure mounting structure of sufficient strength to support the rated capacity of the pintle hook in accordance with S.A.E. J849 and J847.
2. Use the hole pattern template supplied with the pintle hook.
3. Use four 1/2" grade 8 bolts torque to 100 lb.-ft.

### Operating Instructions

1. Before operating, inspect for proper operation, worn, damaged or missing parts and secure mounting. Correct as required before use.
2. Open latch by removing safety pin and lifting lock.
3. Position drawbar eye over the horn of the pintle and lower into place.
4. Push latch closed and insert safety pin, secure pin with spring retainer.

#### **WARNING**

Do not damage the latch. Be particularly careful with the drawbar when coupling and uncoupling



#### **WARNING**

Other steps and inspections are also required. Consult DOT regulations and American Trucking Association for complete coupling and uncoupling procedures.

### Maintenance

For proper performance, perform the following every 3,000 miles or 3 months, whichever comes first:

1. Clean and inspect for proper operation.
2. Inspect, in particular, the coupling area. Replace when wear exceeds 1/8" (.125") from the original surface profile.
3. Inspect for worn, damaged or missing parts. Replace as required.
4. Regularly lubricate latch and lock pivots with a light oil lubricant.
5. Check mounting bolts for proper torque.

### General Information

1. Do not modify or add to the product.
2. Do not weld on this product

#### **WARNING**

It is the user's responsibility to be sure that the pintle hook mounting surface is capable of 6,000 lbs. vertical load and 30,000 lbs. gross trailer weight.

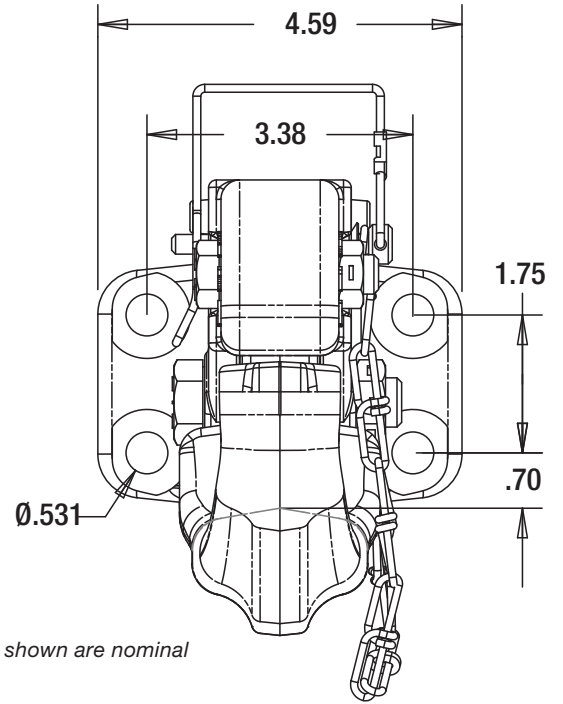
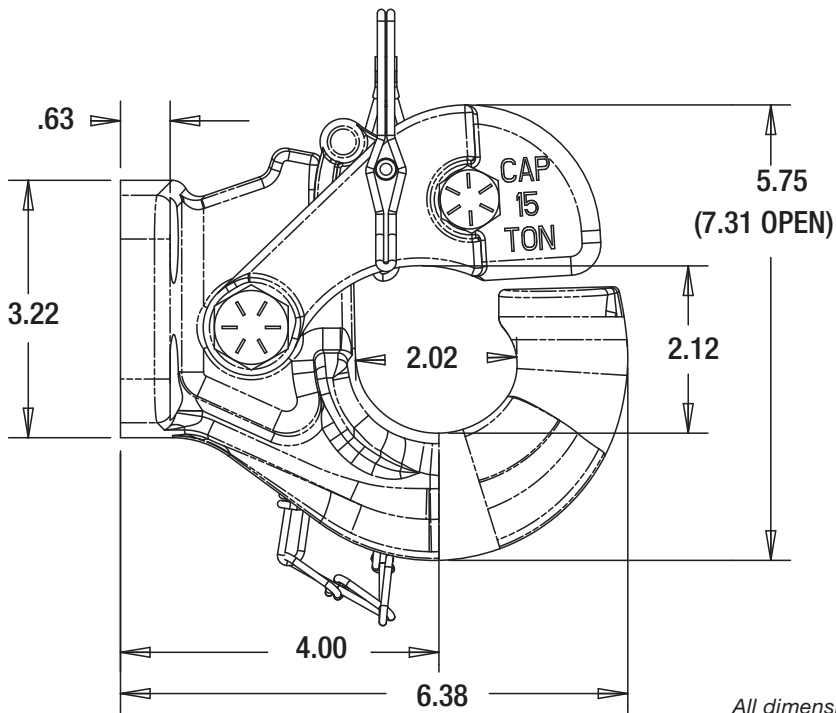

All dimensions shown are nominal

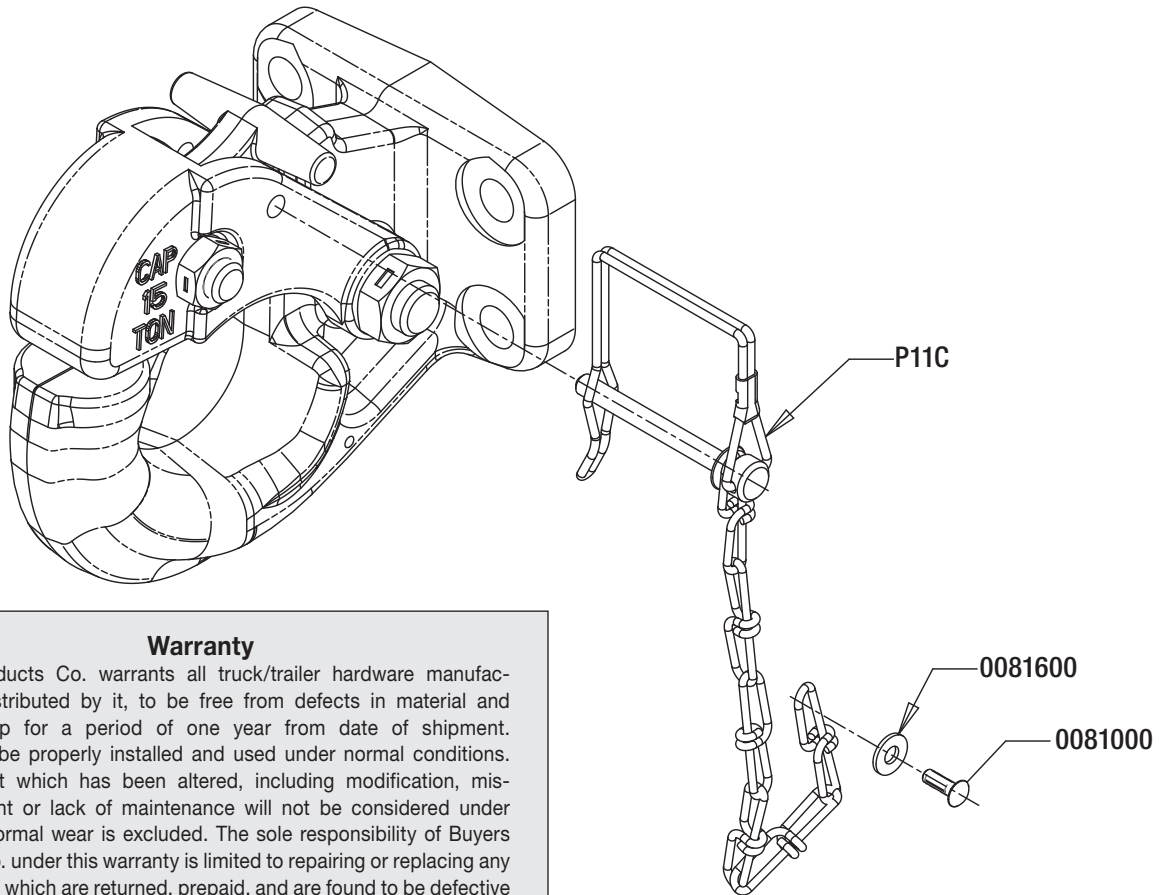

**Warranty**

Buyers Products Co. warrants all truck/trailer hardware manufactured or distributed by it, to be free from defects in material and workmanship for a period of one year from date of shipment. Parts must be properly installed and used under normal conditions. Any product which has been altered, including modification, misuse, accident or lack of maintenance will not be considered under warranty. Normal wear is excluded. The sole responsibility of Buyers Products Co. under this warranty is limited to repairing or replacing any part or parts which are returned, prepaid, and are found to be defective by Buyers Products Co. Authorization from Buyers Products Co. must be obtained before returning any part. No charges for transportation or labor performed on Buyers' products will be allowed under this warranty.