



#4409 Industry Standard Rail Adapter

for use with a Traditional Series SuperGlide hitch in vehicles with any brand industry standard rail system
or with PullRite OE Series Adapters #4439, #4442 & #4444

Check the Parts List quantities below before you begin. Call PullRite Towing Systems at (800) 443-2307 to report any shortage.

1. Remove the existing industry standard hitch from the truck.
2. Bolt the Traditional Series Adapter Rails {A} loosely onto the #4409 Adapter Rails {B}.
3. Install the #4409 Adapter Rail {B} assembly onto your existing base rails and secure by using the base rail pins that fit your current rails. The overhang on the SuperGlide Base Rail Assembly should extend toward the rear of the truck.
4. Install your Traditional Series SuperGlide hitch onto the Adapter Rails {A}, using the Base Rail Pins provided with your hitch. For complete instructions on installing the pins and clips, visit our website at www.pullrite.com.
5. Tighten all bolts to 75 foot pounds.

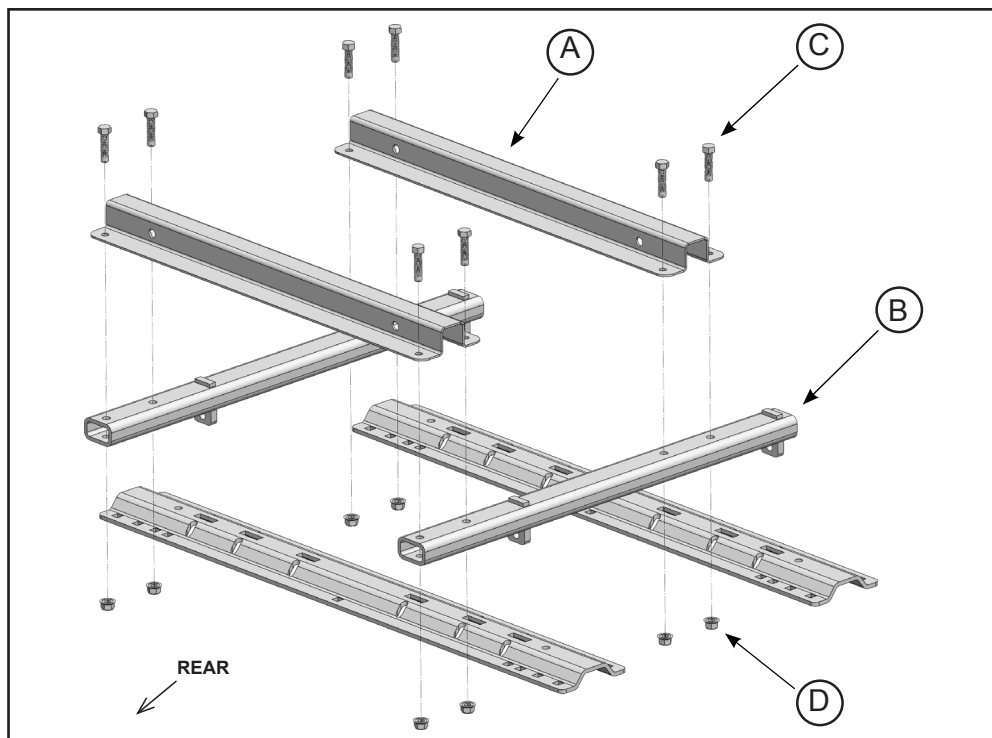

PARTS LIST

item	description	part no.	qty.	
A	TRADITIONAL SERIES ADAPTER RAIL	44090001	2	
B	#4409 ADAPTER RAIL	440901	2	
C	1/2" BASE RAIL BOLT	98010178	8	1/2" - 13 X 2-1/4" GRD #5
D	1/2" FLANGE NUT	98150201	8	1/2" - 13 FLANGE NUT

NOTE: When used with our OE Series Tow Prep Package for Ford and Chevy, we recommend using the inside-most holes of the base rails to prevent interference on the #4442 and the absence of outside mounting slots on the #4444 (see right).

