

**FOR INSTALLATION  
WITH M5 MOUNTING LEGS**

**Hitch Rated for 32,000 lbs,  
Max. Pin Weight 6,400 lbs**

**WARNING:** Under no circumstances do we recommend exceeding the towing vehicle manufacturers recommended vehicle towing capacity. Failure to follow instructions for installation and use may cause property damage, injury or death.

## READ ALL INSTRUCTIONS BEFORE STARTING THE INSTALLATION

**Equipment Required:**

- Fastener kit 30892F
- M13, M24 socket and wrench
- Torque Wrench
- Lithium Grease

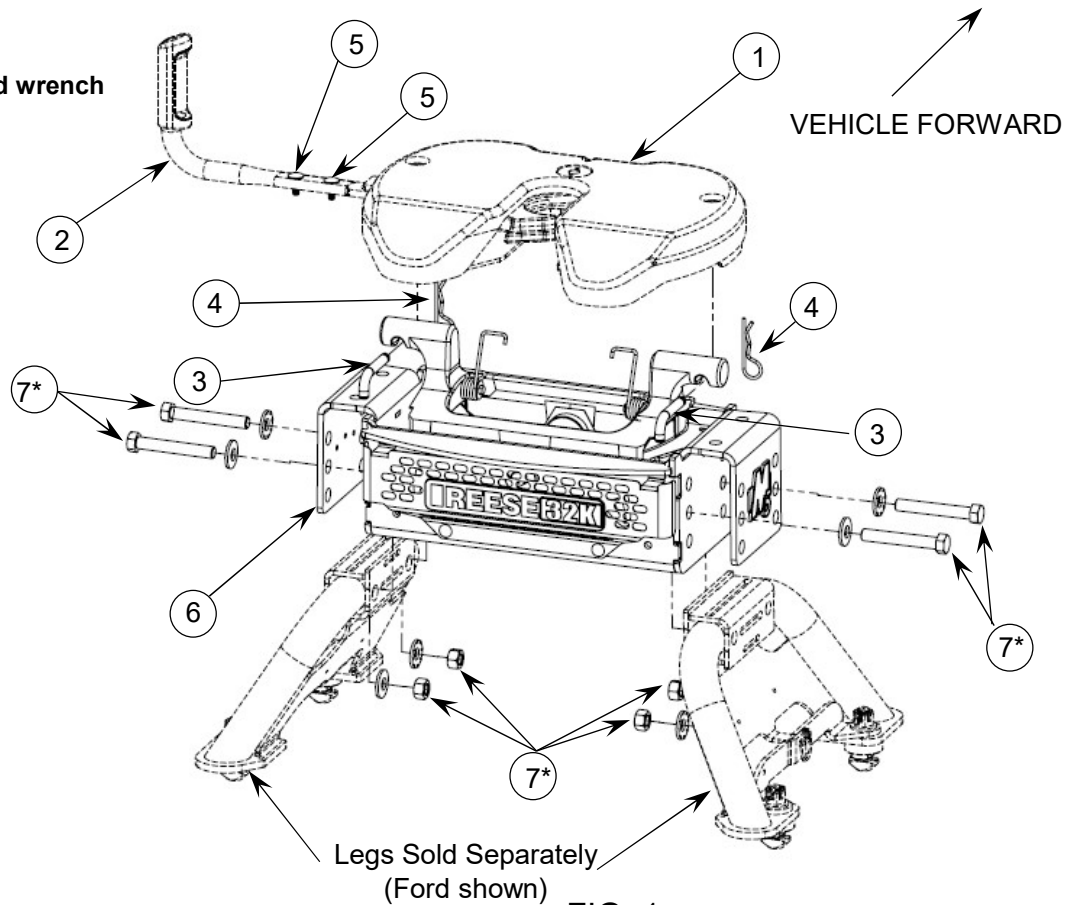

Fasteners shown with (\*) are supplied with leg unit.

FIG. 1

#	Description	Qty.	#	Description	Qty.	#	Description	Qty.
1	Assembly – Head Unit	1	2	Handle	1	3	½” Pull Pin	2
4	Spring Clip	2	5a	M8 Carriage Bolt	2	5b	M8 Lock Washer	2
5c	M8 Nut	2	6	Center Section (30932)	1	7*	Bolts, Nuts & Washers	4

### Table of Contents

<p><b>Assembly.....p 2</b></p> <p><b>Maintenance.....p 3</b></p> <p><b>Head/Handle Position Overview.....p 4</b></p> <p><b>Hitching.....p 5</b></p>	<p><b>Pull Test.....p 5</b></p> <p><b>Unhitching.....p 6</b></p> <p><b>Added Clearance to Cab.....p 7</b></p> <p><b>Warranty.....p 8</b></p>
---	--

**\*Note: Leg Assembly instructions can be found under their individual part number**

## Assembly

### Handle Assembly

1. Slide tube over the bar as shown in figure 2, and securely tighten with carriage bolts, lock washers and nuts with M13 wrench. Handle should be snug.

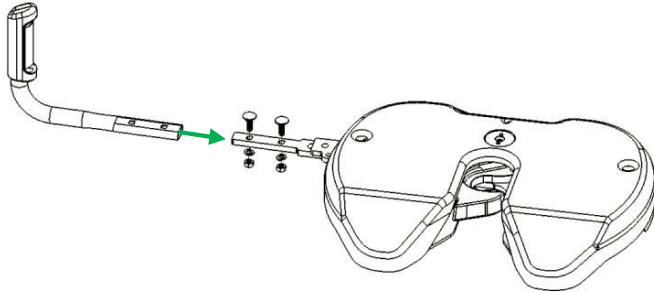

FIG. 2

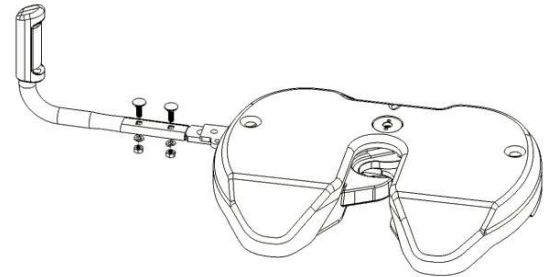

FIG. 3

### Center Section Attachment to Legs

1. Fasteners and assembly instructions are included with the set of legs, sold separately.
2. For height adjustment, the unit should be set to have a minimum of 6" clearance between the truck bed rail and the bottom of the trailer. This unit has 3 possible attachment locations, with 4" of overall adjustment.
3. For added clearance to the truck cab, see page 7.

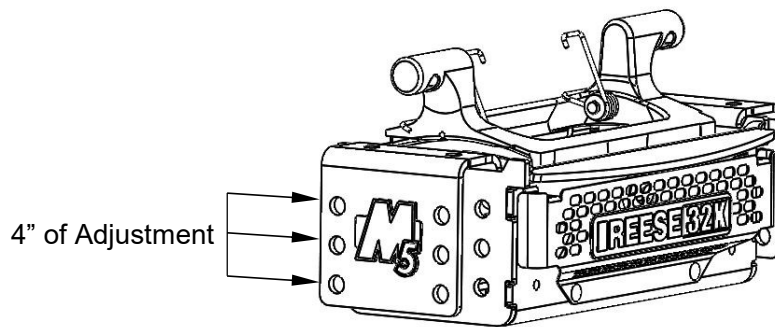

FIG. 4

### Head Attachment to Center Section

1. Apply grease per page 3, figure 9. Place head unit on top of center section, making sure to avoid putting any body parts in pinch points
2. Insert pull pin as shown in figure 6, and secure with spring clips. Both sides required.
3. Inspect through sight holes on top of head pan to make sure clips are assembled correctly, as shown in figure 7

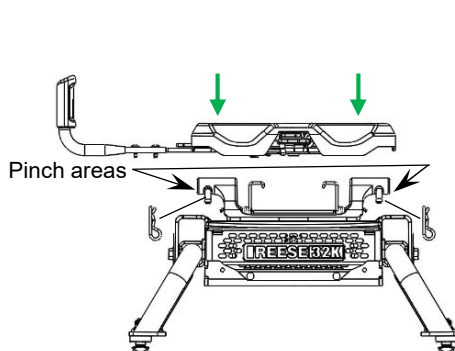

FIG. 5

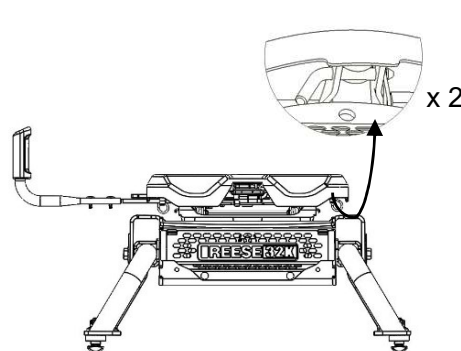

FIG. 6

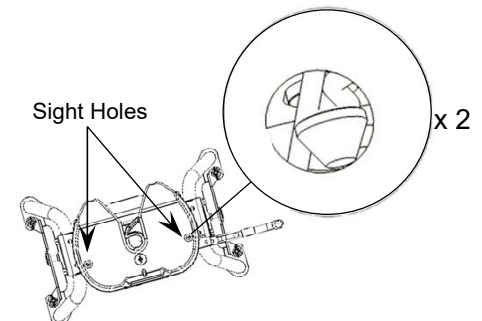

FIG. 7

## Maintenance

This unit is designed to need very little maintenance and be one of the quietest on the market. In order to ensure long term performance, it is recommended to lubricate as indicated below;

### Every Use

1. Apply grease to skid plate surface, to provide lubricated surface for attachment to trailer.  
Note: Plastic lube plates can be used to avoid messy grease. Plate must not exceed 3/16" in thickness to ensure hitch works properly. REESE 5<sup>th</sup> Wheel Lube Plate #83001 is recommended.
2. Apply grease to 5<sup>th</sup> wheel jaw and/or kingpin on the trailer.

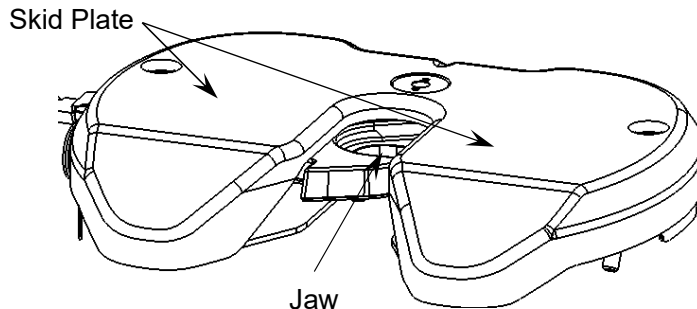
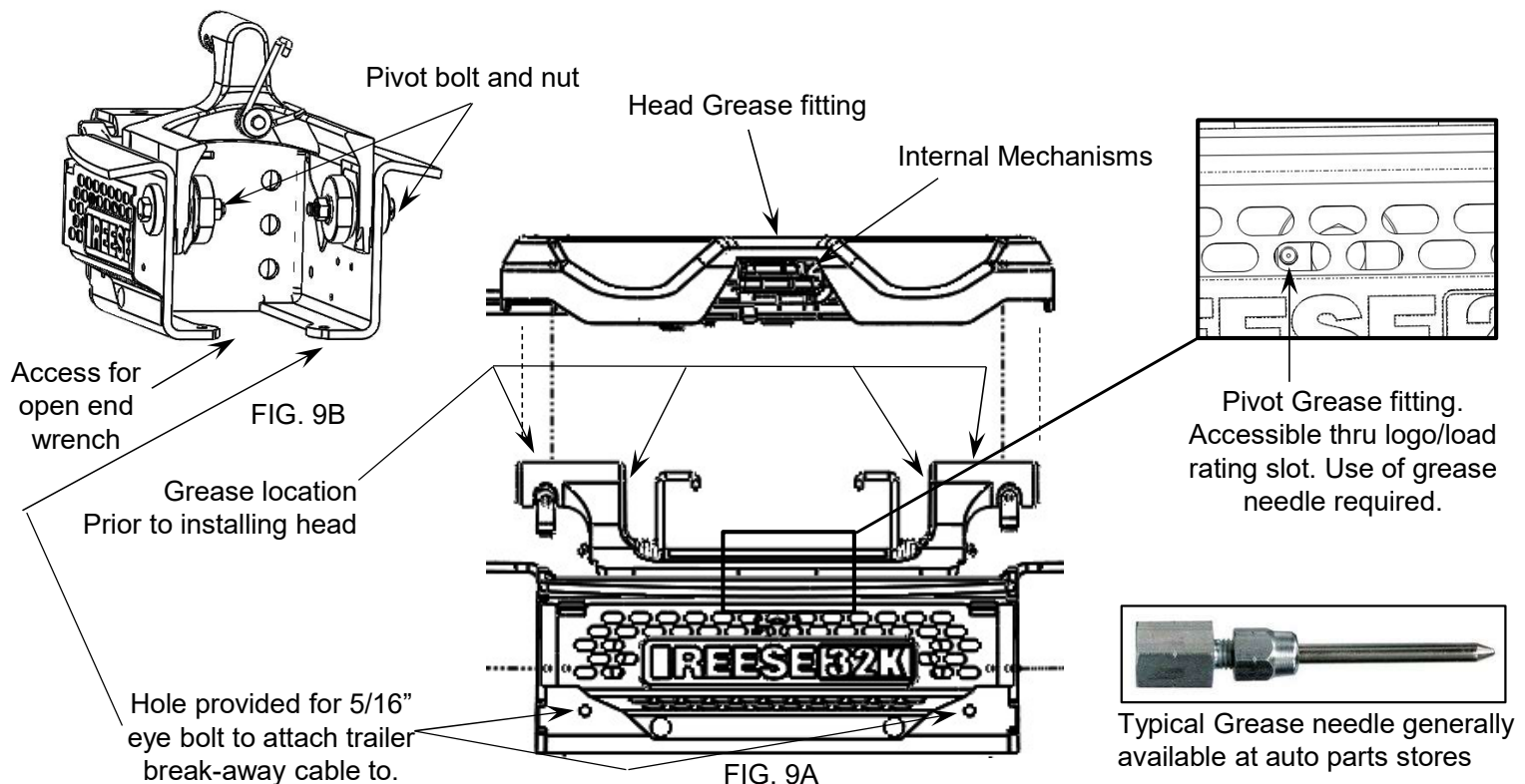

FIG. 8

### Annually/As Required

1. Apply grease via the grease fitting on the top of the unit. (Grease needle required, see fig. 9) Head comes pre-greased
2. Apply spray on white lithium grease to internal mechanisms - rotate handle a few times to distribute the lubricant.  
Note: May need to wipe down unit to remove large debris before application of grease.
3. Greasing the pivot assemblies can easily be done with a grease gun that has a needle adapter installed.
4. The pivot assembly resistance is preset at factory. If head pivots and makes noise when trailer is not attached, adjust the resistance more by tighten pivot bolt 1/2 turn at a time (2 full turns max.). See figure 9B.
5. The pivot assembly can be rebuilt if require. Instructions to do this will be in rebuild kit.



### Functionality Overview

#### Ready-to-Receive Position:

When will the head will be in this posit

- When delivered
- When hitch not in use
- When coupling to trailer
- After uncoupling from trailer

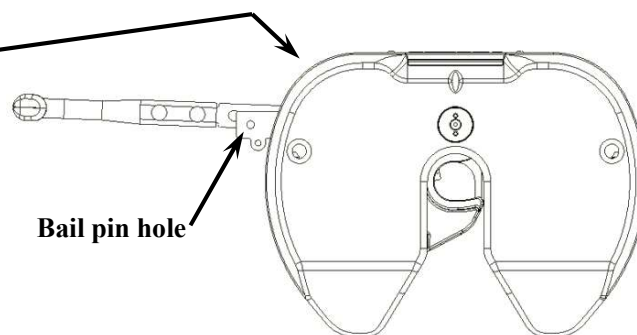

Bail pin hole

FIG. 10

How to tell the head is in this position:

- Handle is pulled out so holes do not align for bail pin
- Handle is easily movable towards cab, and returns to default position upon release
- Indicator shows **RED**

#### Locked Position:

When will the head will be in this positio

- When coupled to trailer

How to tell the head is in this position:

- Handle is in a position that holes align for bail pin insertion.
- Indicator ONLY shows **GREEN**

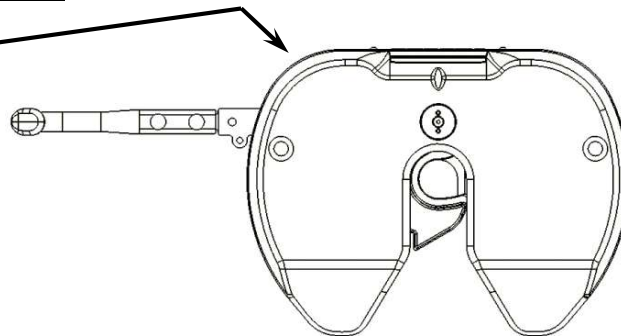
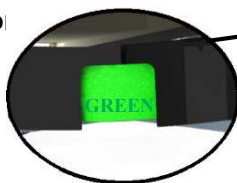

FIG. 11

#### Unhitching Position:

When will the head will be in this position?

- When unhitching the trailer

How to tell the head is in this position:

- Handle is in position shown\*
- Indicator shows **RED**

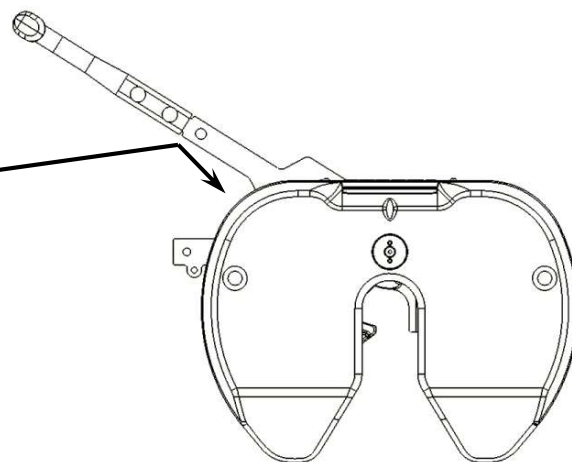

FIG. 12

\*If there is tension between truck and trailer, the truck or trailer may shift when handle is pulled. In this case, handle will start to return to ready-to-receive position, but trailer will still uncouple.

## Hitching Procedure

**Before hitching to a trailer, make sure your 5<sup>th</sup> wheel height is correct.**

**Information on how to properly set the height of your 5<sup>th</sup> wheel hitch can be found in the Leg Installation Instructions.**

**Failure to follow these instructions may result in death or serious injury**

- 1) Make sure truck and trailer is in position to couple
  - A. 5<sup>th</sup> wheel is correctly secured to truck
  - B. Truck tailgate is lowered if necessary
  - C. Blocks/Chocks are firmly against each trailer wheel to prevent any possible forward or rearward motion.
  - D. Pin box is at correct height for hitching (fig. 13 & 14).
  - E. Make sure head is in Ready-to-Receive position (pg. 4, fig.10)

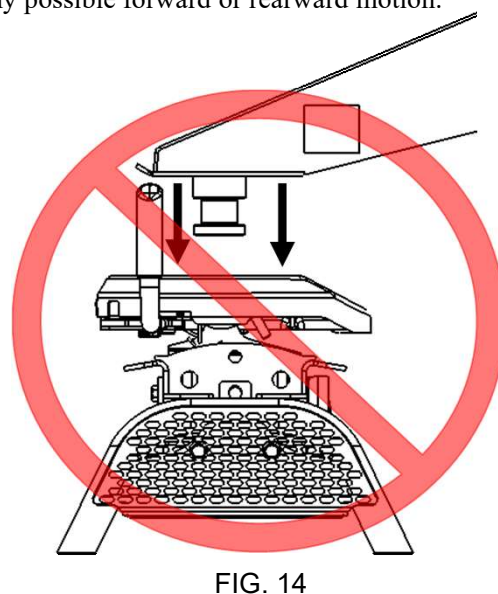
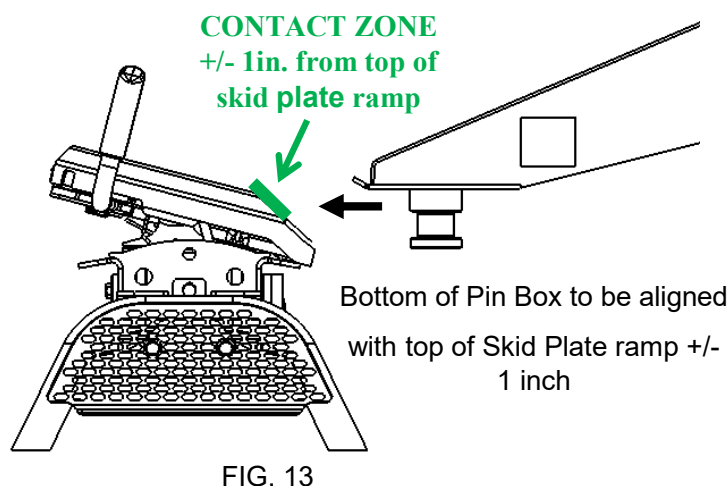

- 2) Back truck slowly into trailer so the trailer king pin and 5<sup>th</sup> wheel funnel align. Hitch will latch automatically when truck is backed completely into trailer king pin. When this occurs, the indicator will be 100% green (pg. 4, fig. 11).\*
- 3) Perform Pull Test –
  - A. With trailer wheels still firmly blocked, trailer landing gears firmly on the ground supporting trailer weight, and trailer brake on, make sure no one is between the truck and trailer.
  - B. Try to pull trailer slowly forward. If trailer is properly hitched, proceed to Step 4. If trailer is not properly hitched, trailer will separate from hitch, and truck will move forward - repeat steps 1 thru 3.
- 4) Insert bail pin into lock hole, as shown in figure 15, or lock for added security. Possible lock dimensions shown on page 6.

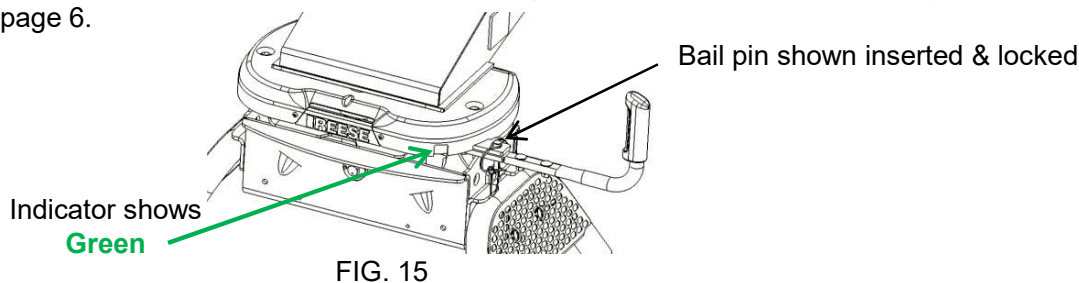

- 5) Connect electrical cable and breakaway switch cable between truck and trailer, raise tailgate if necessary.
- 6) Remove chocks/blocks and lift trailer jacks.

\*Jaw may not close if under compression. If fully backed into trailer and not fully latched, pull truck slowly forward to remove load on jaw. Handle will fully latch.

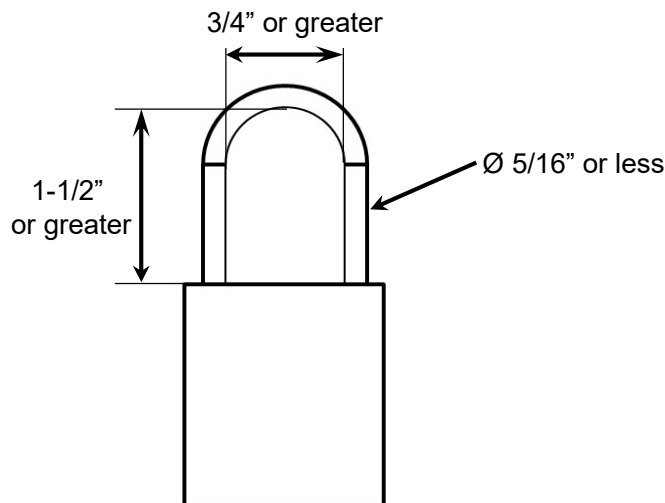

## **Unhitching Procedure**

**Failure to follow these instructions may result in death or serious injury**

- 1) Make sure trailer is secure
  - A. Blocks/Chocks are firmly against each trailer wheel to prevent any possible forward or rearward motion.
  - B. Trailer jacks are lowered and are firmly on the ground
- 2) Make sure truck is ready to unhitch:
  - A. Tailgate is lowered as necessary
  - B. Electrical cable and breakaway switch cable are disconnected.
- 3) As truck and trailer may shift when unhitching, ensure no person or vehicle is in the vicinity of truck or trailer when unhitching
- 4) Remove bail pin from locking hole, and move handle to unhitching position (fig. 17) by pulling out and rotating towards handle towards cab.\*

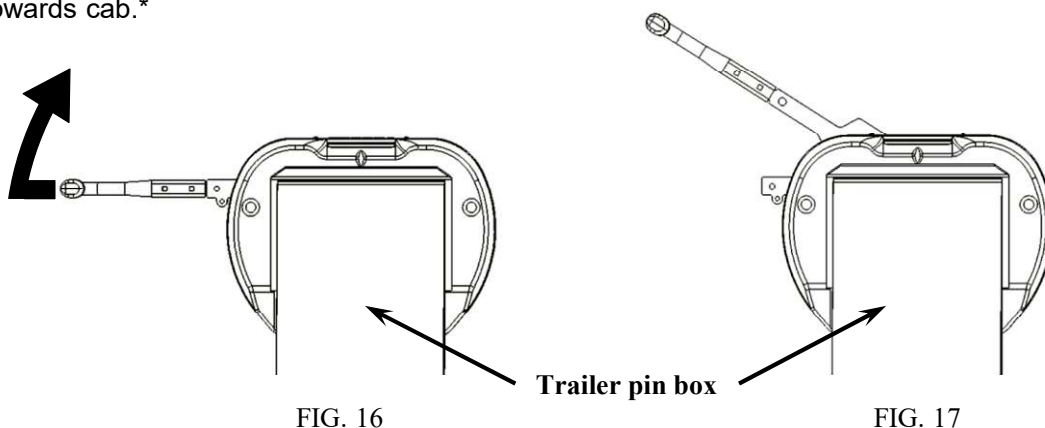

- 5) Drive truck slowly away from trailer

\*If there is tension between truck and trailer, the truck or trailer may shift when handle is pulled. In this case, handle will start to return to ready-to-receive position, but trailer will still uncouple.

### TO INCREASE THE GAP BETWEEN TRAILER AND TRUCK CAB by 1-1/2".

The center section has an option to increase the gap between the trailer front and the truck cab by 1-1/2" by rotating the center section 180 degrees.

Location of king pin should be ahead of truck rear axle and have proper truck cab clearance

1. Remove the head by pulling the spring clips off the head retainer pins. Then pull the head retainer pin out of the head.  
**Hint; A slight push down on the head will help this. Caution, avoid getting fingers pinched.**
2. Lift the head off and set aside.
3. Remove the bolts holding the legs on the center section and rotate the center section (all vehicles), **OR** disconnect the feet from the bed and rotate the center section and leg assembly (not possible with RAM vehicles).
4. Re connect the center section or the center section and leg assembly per the installation instructions of that portion.
5. Remove the logo/rating cover by gently prying the two lower plastic retainers with the cover away from the center section. Avoid scratching the paint by using plastic auto trim tools. The top will pivot and pull away once the cover rotates up enough.
6. Re-install on the other side (truck rear) by reversing the above process.
7. Remove the head springs by removing the 1/4" bolt (7/16" socket) and flip them from right to left. When installed properly, the springs should be pointing up towards the truck cab and tighten to 7-8 ft-lbs. Springs will flex freely.
8. Re apply grease to the head and center section interface and re-install the head per instructions.  
**Caution; place hands or fingers on either side of the pivot interface to prevent pinching.**
9. Re-install head retainer pins and clips per head instructions.

\*30894 27k Center section shown

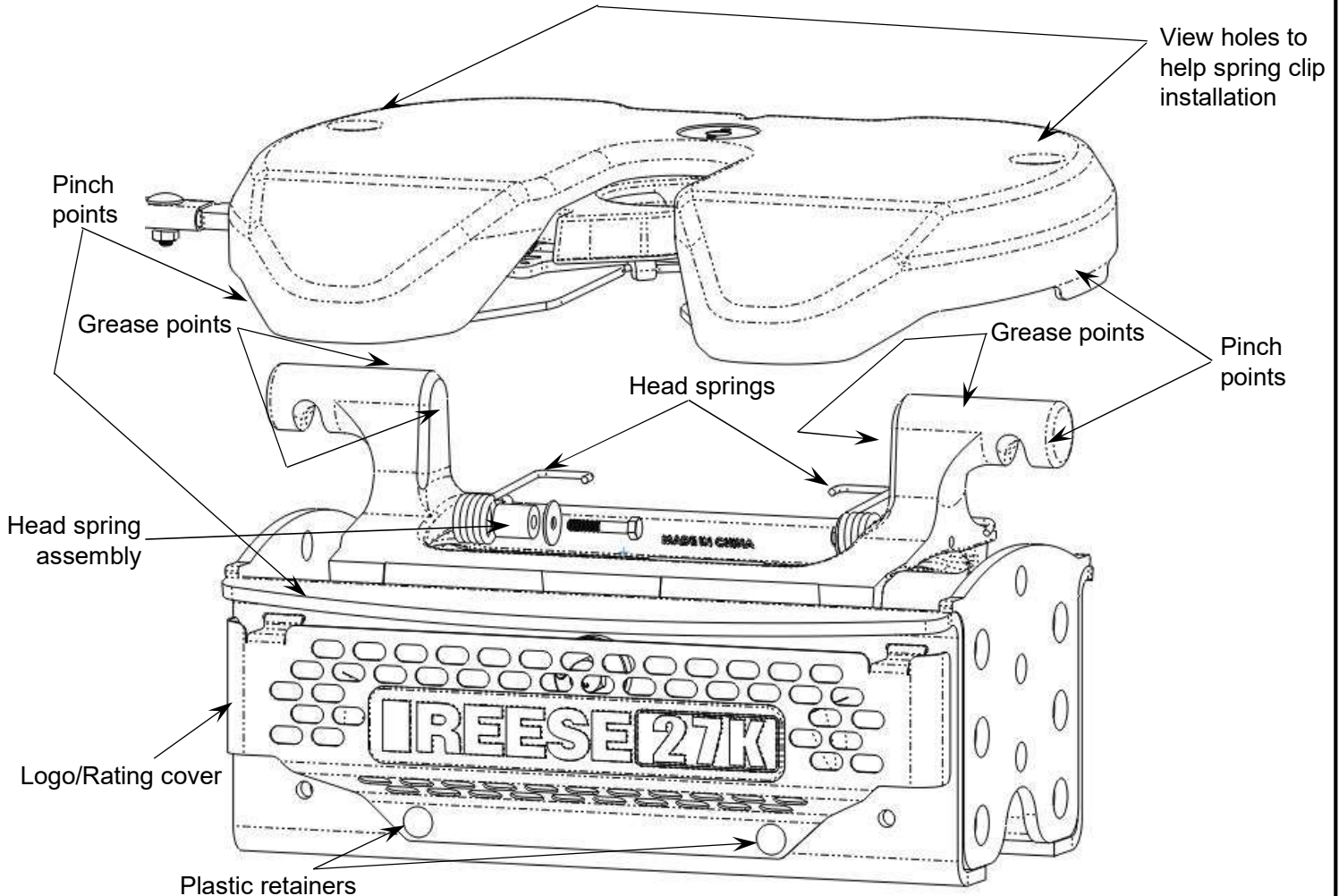

FIG. 18

Shown in factory location with offset towards cab of truck

# Product Instructions:

## Head & Center Section

Part Number Purchased: Place of Purchase: Date of Purchase: Part Manufactured Date (located on driver-side sticker):
---

**NOTES:**

---

---

---

---

---

---

---

---

---

---

---

---

---

---

---

### LIMITED LIFETIME WARRANTY

- Limited Lifetime Warranty** (“Warranty”). Horizon Global (“We” or “Us”) warrants to the original consumer purchaser only (“You”) that the product will be free from material defects in both material and workmanship for a period of lifetime of ownership, ordinary wear and tear excepted; provided that installation and use of the product is in accordance with product instructions. There are no other warranties, express or implied, including the warranty of merchantability or fitness for a particular purpose. This warranty is not transferable.
- Limitations on the Warranty.** This Warranty does not cover: (a) normal wear and tear; (b) damage through abuse, neglect, misuse, or as a result of any accident or in any other manner; (c) damage from misapplication, overloading, or improper installation; (d) improper maintenance and repair; and (e) product alteration in any manner by anyone other than Us, with the sole exception of alterations made pursuant to product instructions and in a workmanlike manner.
- Obligations of Purchaser.** To make a Warranty claim, contact Us at 47912 Halyard Drive Suite 100, Plymouth, MI, 48170, 1-800-632-3290, identify the product by model number, and follow the claim instructions that will be provided. Any returned product that is replaced by Us becomes our property. You will be responsible for return shipping costs. Please retain your purchase receipt to verify date of purchase and that You are the original consumer purchaser. The product and the purchase receipt must be provided to Us in order to process Your warranty claim.
- Remedy Limits.** Product replacement is Your sole remedy under this Warranty. We shall not be liable for service or labor charges incurred in removing or replacing a product or any incidental or consequential damages of any kind.
- Assumption of Risk.** You acknowledge and agree that any use of the product for any purpose other than the specified use(s) stated in the product instructions is at Your own risk.
- Governing Law.** This Warranty gives You specific legal rights, and You also may have other rights which vary from state to state. This Warranty is governed by the laws of the State of Michigan, without regard to rules pertaining to conflicts of law. The state courts located in Oakland County, Michigan shall have exclusive jurisdiction for any disputes relating to this Warranty.

Horizon Global America, Inc  
47912 Halyard Drive Suite 100  
Plymouth, MI 48170

