

*** DO NOT EXCEED VEHICLE MANUFACTURER'S RECOMMENDED TOWING CAPACITY.***

HAVING INSTALLATION QUESTIONS? CALL TECHNICAL SUPPORT AT 1-877-287-8634

Parts List			
ITEM	QTY	PART NUMBER	DESCRIPTION
1	10	CM-SP33	.250 x 1.50 x 2.00" SQUARE HOLE SPACER
2	7	CM-SP136	.313" x 1.00 x 2.00" U-SHAPE SPACER
3	2	CM-1208-UBS	1/2-13 x 4 1/8 x 6 x 1 1/2 SQ U-BOLT
4	10	10-10288	BOLT, CAR, 1/2-13 UNC, 2, GRD8, YZ
5	10	20-00062	NUT, SER-FLANGE, 1/2-13 UNC, GRD8, YZ
6	4	20-00005	NUT, FLANGE, 1/2-13, GRD5
7	2	CM-SP9	.375 x 1.25 x 2.50" SQUARE HOLE SPACER
8	2	5_8 FISHWIRE	5/8" FISHWIRE
9	2	10-10118	BOLT, CAR, 5/8-11 UNC, 1-3/4, GRD8
10	2	20-00105	NUT, SER-FLANGE, 5/8-11 UNC, GRD8, YZ
11	3	CM-SP56	.375 x 1.25 x 2.00" ROUND HOLE SPACER

NOTE: NOT ALL HARDWARE WILL BE USED

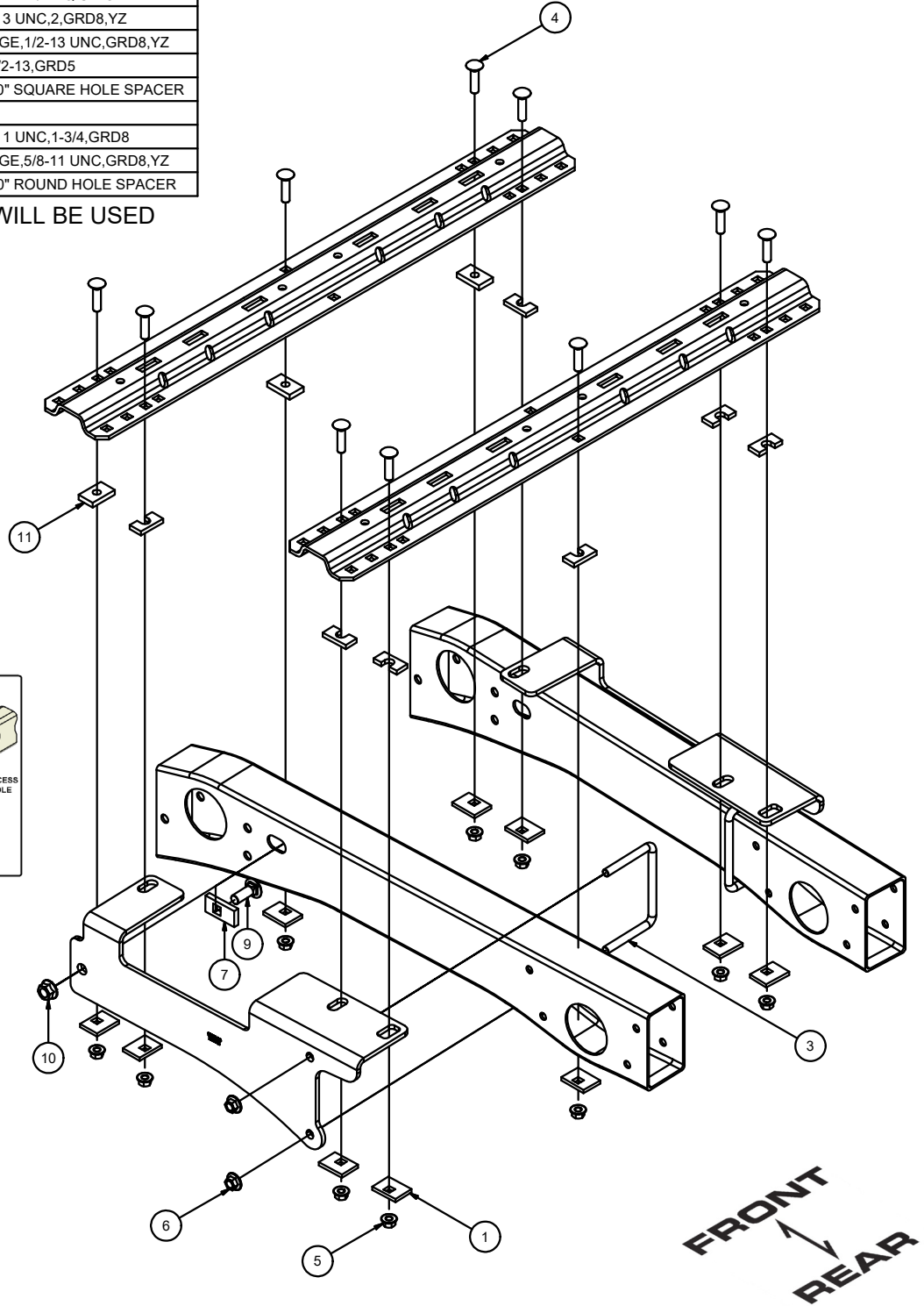

FISHWIRE TECHNIQUE

INSERT COILED END OF FISHWIRE TOOL THROUGH HITCH MOUNTING HOLE IN VEHICLE FRAME RAIL AND OUT THE ACCESS HOLE. PASS COILED END OF FISHWIRE THROUGH SPACER AND THREAD BOLT INTO COIL. KINK WIRE TO KEEP SPACER SEPARATE FROM BOLT AS SHOWN. PULL FISHWIRE, SPACER, AND BOLT THROUGH FRAME AND OUT MOUNTING HOLE. USE FISHWIRE TO GUIDE HITCH DURING MOUNTING AND PREVENT LOSS OF BOLT / SPACER INSIDE FRAME RAIL.

NOTE: SOME VEHICLES MAY FISHWIRE THROUGH END OF FRAME

TOOLS REQUIRED

- RATCHET
- 3" & 6" SOCKET EXTENSION
- TORQUE WRENCH
- CRESCENT WRENCH
- 3/4" BOX END WRENCH
- 13mm, 24mm, 3/4", 15/16" SOCKETS
- DRILL
- 1/8" AND STEP DRILL BITS
- SAFETY GLASSES

HITCH WEIGHT: 26 LBS.

INSTALL TIME

PROFESSIONAL: 40 MINUTES

NOVICE (DIY): 80 MINUTES

INSTALL NOTES:

- FISHWIRE HARDWARE
- NO DRILLING REQUIRED

PERIODICALLY CHECK THIS RECEIVER HITCH TO ENSURE THAT ALL FASTENERS ARE TIGHT AND THAT ALL STRUCTURAL COMPONENTS ARE SOUND.

Curt Manufacturing Inc., warrants this product to be free of defects in material and/or workmanship at the time of retail purchase by the original purchaser. If the product is found to be defective, Curt Manufacturing Inc., may repair or replace the product, at their option, when the product is returned, prepaid, with proof of purchase. Alteration to, misuse of, or improper installation of this product voids the warranty. Curt Manufacturing Inc.'s liability is limited to repair or replacement of products found to be defective, and specifically excludes liability for incidental or consequential loss or damage.

HAVING INSTALLATION QUESTIONS? CALL TECHNICAL SUPPORT AT 1-877-287-8634

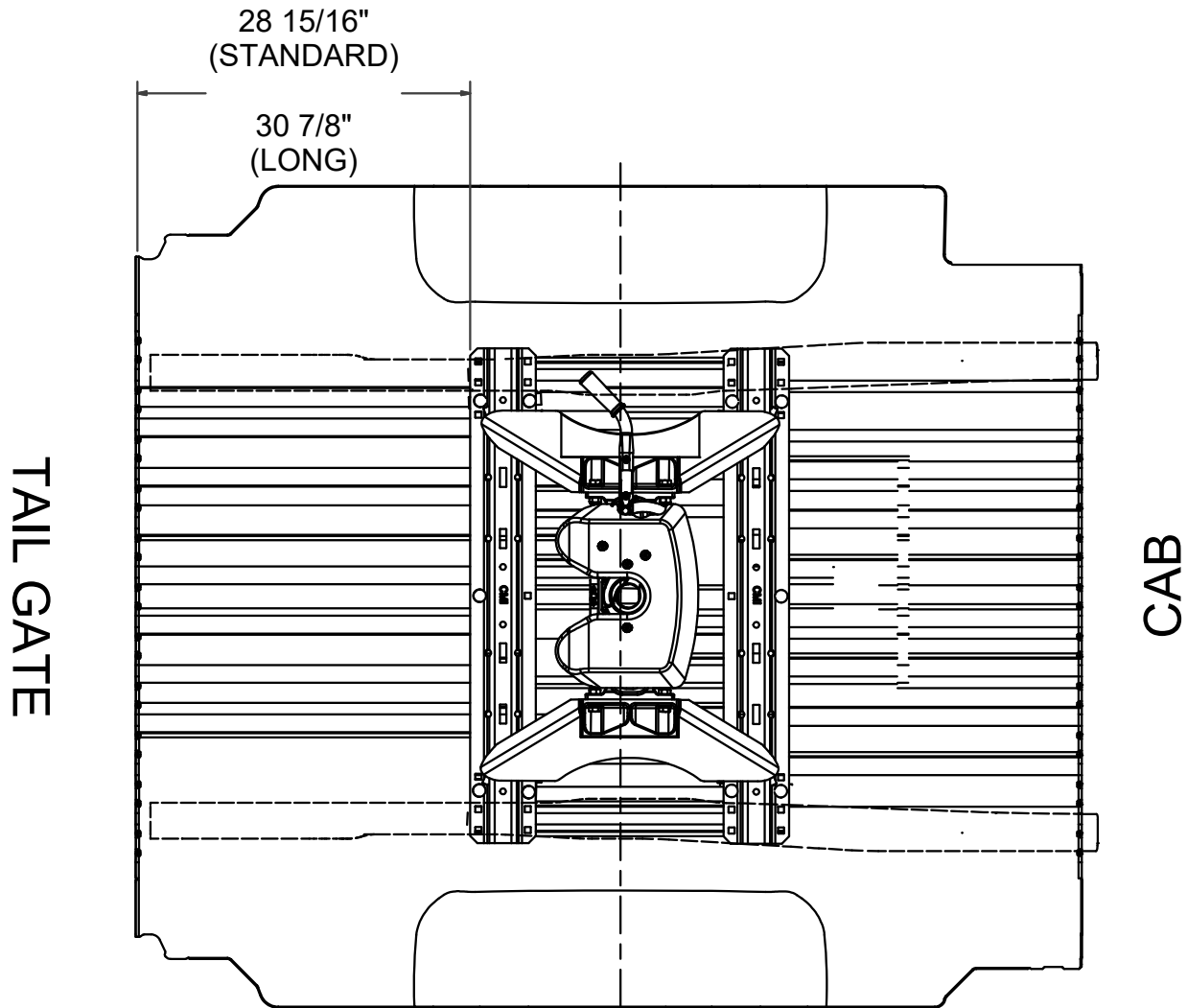

AXLE CENTER LINE

****BE SURE TO COMPENSATE FOR THE THICKNESS OF THE SPRAY-IN BED LINER IF PRESENT****

SHOWN WITH CURT 16180 5TH WHEEL

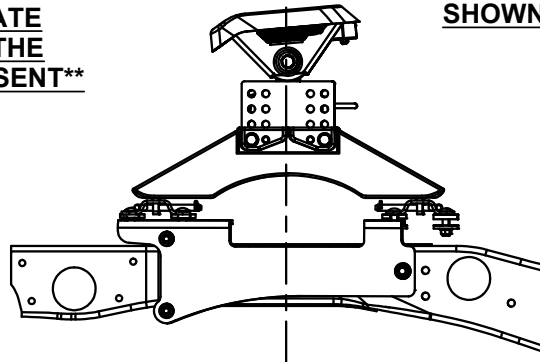

PERIODICALLY CHECK THIS RECEIVER HITCH TO ENSURE THAT ALL FASTENERS ARE TIGHT AND THAT ALL STRUCTURAL COMPONENTS ARE SOUND.

Curt Manufacturing Inc., warrants this product to be free of defects in material and/or workmanship at the time of retail purchase by the original purchaser. If the product is found to be defective, Curt Manufacturing Inc., may repair or replace the product, at their option, when the product is returned, prepaid, with proof of purchase. Alteration to, misuse of, or improper installation of this product voids the warranty. Curt Manufacturing Inc.'s liability is limited to repair or replacement of products found to be defective, and specifically excludes liability for incidental or consequential loss or damage.

HAVING INSTALLATION QUESTIONS? CALL TECHNICAL SUPPORT AT 1-877-287-8634

!WARNING!

- Do not install mounting rails over plastic bed liners. Plastic liners must be trimmed for metal-to-metal contact. May be installed on spray in liner.
- Use only supplied fasteners for installation.
- Before installing hitch measure to be sure there will be enough clearance between the truck and trailer to allow for turns.
- Frame rail must be clear of any electrical or brake components where side plates attach.

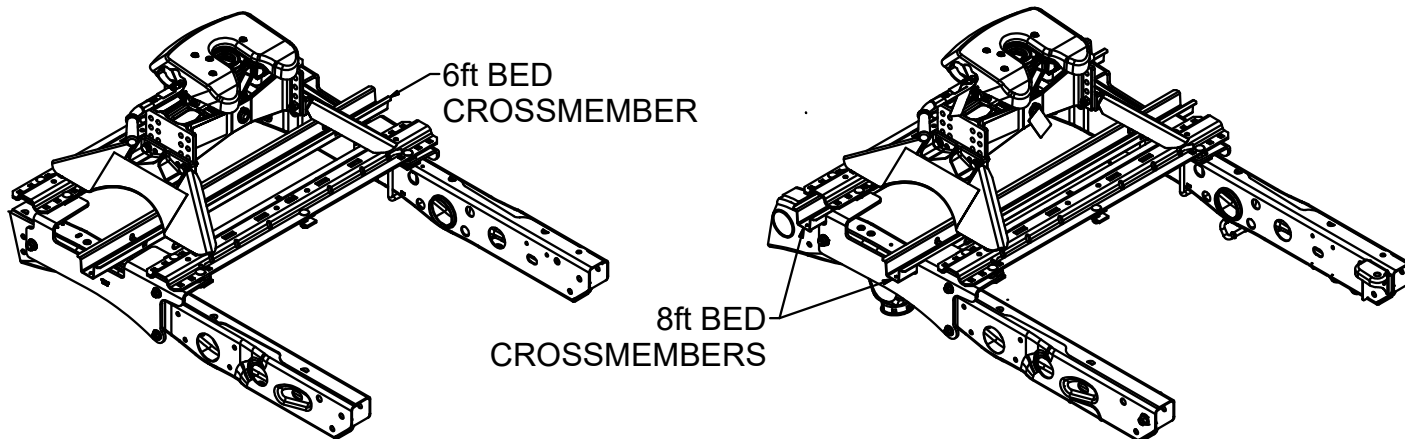

INSTALLATION STEPS

1. Place one mounting rail in the box of the truck, using your tape measure, center the rail on the truck box floor at the proper distance from the rear edge of the truck box as shown on the "RAIL LOCATION DIAGRAM" on page 2.
2. Remove inner fender liner (if present) by removing (4) screws and (3) plastic fasteners spare tire and exhaust heat shield.
3. Using a center punch, mark the holes as per the rail location diagram. Drill (1) hole first and check by temporarily positioning the side plate on the side of the frame. Move the mounting rail out of the way and drill each position with a 1/8" drill bit.
4. Temporarily position the side plates on the sides of the frame and check that all the 1/8" drilled holes align with the slots of the side plates. Remove the side plates from the vehicle.

NOTE: Move any electrical or braking components that may be trapped between the frame and side plates.

5. Enlarge the 1/8" drill holes to 9/16" with a step drill bit.
6. Reverse fishwire 5/8" carriage bolts and CM-SP9 spacers through the access hole and into position, as shown on page 1. Leave fishwires attached and raise the side plate into position. Finger tighten the side plate to the side of the frame using the 5/8" flange nuts. See "FISHWIRE TECHNIQUE" on page 1. Repeat on other side. Raise side plate into position and use (1) 1/2" U-Bolt, and (2) 1/2" flange nuts to attach side plate to frame as shown on page 1. Repeat on other side.
7. Reposition the mounting rail over the holes and fasten the mounting rail to the side plates using the supplied 1/2" carriage bolts. Use the supplied CM-SP33 and CM-SP136 spacers between the frame bracket or mounting rails and the truck box to ensure a metal to metal contact and to eliminate "rib crush" of the bed. Use of a ratcheting wrench will ease the tightening process.
8. Place the unassembled 5th wheel / roller / gooseneck hitch into the already installed mounting rail. Position the second mounting rail with the 5th wheel / roller / gooseneck hitch by inserting the tabs into the mounting rail and pushing the mounting rail tight towards the other mounting rail. Ensure that the mounting rail is centered on the truck box floor. This will position the rail in the correct location and ensure that the 5th wheel will have a snug fit to the truck. To ease the process of tightening rear fasteners remove the spare tire and fasteners from heat shield.

NOTE: If more than one hitch product will be used with the mounting rails then both should be used at the same time to align the second mounting rail. This will ensure that one product does not compromise the fit of the other.

9. Repeat steps 3, 4, 5, 6 and 7
10. Torque all 1/2" hardware to 110 ft-lbs but torque the U-bolts to 75 ft-lbs. Torque all 5/8" hardware to 210 ft-lbs. Reinstall inner fender liner, spare tire and exhaust heat shield removed in step 2.

PERIODICALLY CHECK THIS RECEIVER HITCH TO ENSURE THAT ALL FASTENERS ARE TIGHT AND THAT ALL STRUCTURAL COMPONENTS ARE SOUND.