



## 2-Point Weight Distributing Hitch Owner's Manual & Installation Instructions

Serial Number



### Standard Receiver, Round Bars, and L Brackets

**BXW0675**

600 lbs. maximum tongue weight capacity

**BXW0875**

800 lbs. maximum tongue weight capacity

**BXW1275**

1,200 lbs. maximum tongue weight capacity

**\*2" x 7.5K rated chrome plated hitch ball included with the BXW0675 kit**

**\*2-5/16" x 12K rated chrome plated hitch ball included with the BXW0875  
and BXW1275 kits**

## ***THANK YOU***

*for purchasing from Blue Ox®. Please read the manual to insure your  
installation is as simple and trouble-free as possible. Keep your sales receipt  
and the manual in a safe place for future reference.*

## Welcome to the Blue Ox<sup>®</sup> Family

The 2-Point WD Hitch is a revolutionary hitch that not only handles weight distribution but sway control as well by using the combination of loaded spring bars and friction L brackets. As the trailer tries to sway the steel on steel friction of the L brackets works to control trailer sway. The 2-Point WD Hitch will also conquer weight distribution at the same time, putting more weight on the towing vehicle's front tires which increases steering control and braking giving you a safer and easier driving experience. Your 2-Point WD Hitch is backed by a limited lifetime limited warranty. **Any unauthorized modifications to your 2-Point WD Hitch may void the warranty.**

Please read all of the technical documents, warnings, tips, and notes in this manual before operating your 2-Point WD Hitch for the first time. Improper installation, use and/or maintenance may result in malfunction causing personal injury or property damage. Please fill out and return your warranty card.

### Features & Benefits

- **Hitch Ball Included & Installed**  
A 2-5/16" x 12K rated chrome plated hitch ball comes included and installed with the BXW0875 and BXW1275 kits and a 2" x 7.5K rated chrome plated hitch ball is included and installed with the BXW0675 kit.
- **Powder Coat Finish**  
The powder coat finish provides a professional appearance, aids in rust prevention, and prolongs the life of the product.
- **Built-In Weight Distribution & Sway Control**  
Weight distribution and sway control are built into the 2-Point WD Hitch with the hassle of chains or additional sway control.

### Frequently Asked Questions

*What is gross trailer weight?*

**Answer:** Weight of trailer (dry) + liquids (water, propane, sewage) + cargo. Measure gross trailer weight with a fully loaded trailer on a level surface, preferably on a public truck scale.

*What is tongue weight?*

**Answer:** Downward force exerted on the hitch ball by the trailer ball coupler. Measure tongue weight with a fully loaded trailer on a level surface with trailer ball coupler at tow height.

*Does sway control require adjustment?*

**Answer:** Yes, adjustments may be necessary as tongue weight increases or decreases.

*Why do the bars bend? Will they stay bent?*

**Answer:** The spring bars are designed to deflect on a properly set system. This creates the necessary load on the spring bars to achieve an enjoyable ride. No, the spring bars will always return back to straight.

### Things To Know

The towing vehicle's loaded ball height should never be greater than its uncoupled height. Front wheel overload and loss of rear wheel traction can occur and can lead to unstable handling, reduced braking ability, and a tendency to jackknife when turning and braking at the same time.

**DO NOT** attempt to tow any type of trailer behind another trailer. Towing multiple trailers may cause severe instability, loss of control and/or structural failures.

Handling and control of your towing vehicle and trailer is greatly improved when the cargo is properly loaded and distributed. It is recommended to have a tongue weight of 10-15% of the gross trailer weight.

Always use safety chains while towing. Cross chains under the coupler for proper installation and to prevent tongue from dropping to the ground. Only allow enough slack in chains for tight turns, the chains should not drag on the ground. To alleviate slack, twist chains equally from the hook end. Safety chains should be rated at equal to or greater than twice the maximum gross trailer weight rating (GTWR).

**Note:** Regularly check the condition of all towing equipment and reference hitch maintenance information to keep equipment in proper working order and to ensure safety.

**Tools Required**

- 1-1/8" Wrench
- 1-1/8" Socket
- 3/4" Socket
- 15/16" Wrench
- Measuring Tape
- Torque Wrench

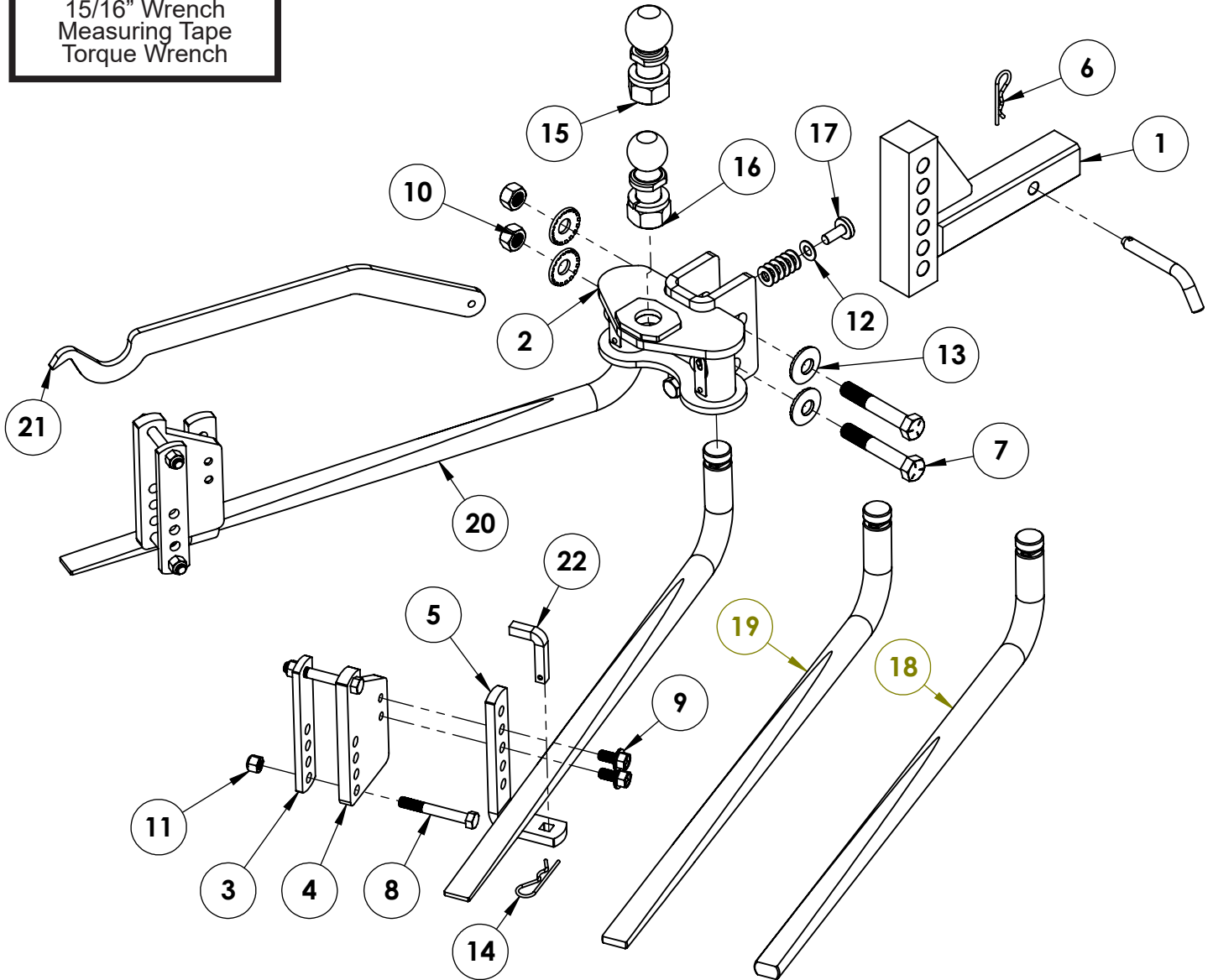

Note: Items #18 thru #20 depend on your 2-Point model

## 2-Point WD Hitch Owner's Manual & Installation Instructions

Item No.	Part No.	Description	Qty.
1.....	61-8428 .....	6 Hole Shank .....	1
2.....	62-4295 .....	Hitch Head Assembly.....	1
3.....	101-10549 .....	Backing Plate.....	2
4.....	101-10677 .....	Offset L Bracket Mounting Plate .....	2
5.....	101-10680 .....	L Bracket Plate .....	2
6.....	200-1483 .....	5/8" x 3" Eff. Pin with Clip .....	1
7.....	201-0372 .....	3/4"-10 x 4-1/2" Hex Head Bolt, Grade 5, ZP .....	2
8.....	201-0851 .....	1/2"-13 x 3-3/4" Hex Head Bolt, Grade 5, ZP .....	4
9.....	201-1014 .....	1/2"-13 x 1" Whiz Flange Bolt .....	4
10.....	202-0007 .....	3/4"-10 Hex Nut, ZP .....	2
11.....	202-0094 .....	1/2"-13 Hex Nylon Insert Lock Nut, ZP .....	4
12.....	203-0168 .....	1/2" Flat Washer, ZP, SAE .....	7
13.....	203-0201 .....	3/4" Serrated Belleville Washer .....	4
14.....	220-0069 .....	9/64" x 3-3/8" Reusable Cotter Pin, ZP.....	2
15.....	229-1166.....	2-5/16" x 1-1/4" Shank Chrome Hitch Ball, 12K.....	1
16.....	229-1171.....	2" x 1-1/4" Shank Chrome Ball, 7.5K (BXW0675 Only)..	1
17.....	299-0833 .....	Head Tilt Pin .....	1
18.....	299-0834 .....	1,200 Lb. Spring Bar (BXW1275) .....	2
19.....	299-0835 .....	800 Lb. Spring Bar (BXW0875) .....	2
20.....	299-0836 .....	600 Lb. Spring Bar (BXW0675) .....	2
21.....	299-0837 .....	Spring Bar Lift Tool, ZP .....	1
22.....	299-0856 .....	1/2" Retaining Key .....	2

### **Important:**

Use only genuine factory replacement parts on your 2-Point WD Hitch. Do **NOT** substitute homemade or non-typical parts. If a bolt is lost or in need of replacement, for your safety and the preservation of your 2-Point WD Hitch, be sure to use a replacement bolt of the same grade (In most cases it will be Grade 5, please reference the parts list above). Replacement parts may be ordered through your nearest Blue Ox® Dealer or Distributor. Failing to follow and/or altering these installation instructions in either installation or required equipment will void the manufacturer's warranty.

## Installation

1. Park the towing vehicle and trailer in a straight line on firm, level ground. Air-ride shock absorbers, air springs, or automatic leveling systems on towing vehicle should be disabled or deflated to the manufacturer's minimum recommended pressure prior to installation. If needed unhook the trailer from the towed vehicle and level. Remove the existing receiver hitch.
2. Insert the hitch receiver shank into the towing vehicle receiver and secure with the 5/8" x 3" pin and clip.
3. Level the trailer using the trailer tongue jack and then measure the coupler height from the ground to the inside of the coupler.
4. Measure the ball height. The ball height should be the same height or 1" higher than the trailer coupler height, adjust as necessary. Start (1) 3/4"-10 bolt into bottom hole.

**Note:** Ram Truck owners please reference the Trailer Towing section of your vehicle owner's manual for proper hitch set-up instructions. Also, it is recommended for optimal towing performance to set the ball height 2" higher than the top the trailer coupler.

5. The hitch ball should be vertical or slightly tilted rearward for proper set up. Adjust the ball angle by adding or removing the number of washers to the tilt head pin. Start with five (5) washers and adjust as needed. Add more washers when close to the maximum tongue weight and fewer washers when close to minimum tongue weight.
6. Once the hitch head tilt has been adjusted insert one (1) 3/4"-10 bolt, 3/4" lock washer and 3/4"-10 hex nut into the top hole. Then remove the bottom 3/4" bolt and add 3/4" lock washer and 3/4"-10 hex nut. Do not fully tighten at this time.
7. Insert the 5/8" bolt in to the bottom front hole on the receiver and tighten against the shank. The hitch head should move upward till the tilt head pin touches the shank. Turn bolt an additional 1/4 to 1/2 turn to fully tighten.
8. Torque the 3/4"-10 bolts to 257 ft/lbs.
9. Couple the trailer to the hitch head by placing the trailer coupler onto the hitch ball per the manufacturer's instructions.

Continued on page 6

## Installation Continued

10. Measure 24"-27" back from the center of the ball coupler and mark this point on the trailer tongue frame on both sides. Center the L bracket mounting holes on the backing plate over the marked area so that the offset is towards the front of the trailer on each side. Both backing plates should be an equal distance from the ball coupler. Remove or relocate any obstructions on the trailer tongue framework if necessary. Finger tighten the bolts on the backing plates at this time. Bottom bolt should be inserted in hole closest to the bottom of the trailer frame. (Figure 1, PS backing plate is shown)

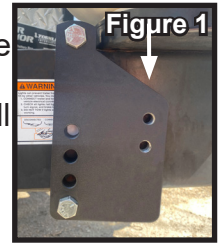

**Note:** If your trailer has bottom-mount coupler, you may need to purchase longer L brackets, part number BXW4069.

**Note:** If the brackets need to be moved due to obstructions, they should be installed between 24"-27" from the center of the ball coupler. For trailers with a tongue weight less than 800 lbs, brackets may need to be installed closer to the center of the ball coupler, with a minimum of 20" from center. If the bracket is not mounted at 27" this may affect the weight distribution set-up, spring bar set-up, and ride stiffness.

11. Apply molybdenum grease to the round end of both spring bars. Push the round end of the bar up into the head socket until a "click" sound is heard. This sound indicates that the bar is locked in place. Do this for both bars.

**Note:** The spring bars can be released in two ways.

First, lift up slightly on the bar and pull gently outward on the retaining pin on the hitch head. The bar should drop free of the hitch head.

Second, rotate the bar away from the trailer and perpendicular to the tow vehicle. Push bar down to remove.

12. The end of the spring bar should be a minimum of 4" from the center of the L bracket backing plate to the open end of the bar. After verifying that the L brackets are 24"-27" from the center of the coupler, fully tighten the 1/2" hex head bolts against the trailer tongue framework. (**Do NOT use Loctite® Red**)

13. Install L brackets onto backing plate by inserting the two (2) 1/2" whiz flange bolts leaving the top hole open on the L bracket. Apply Blue Loctite to the threads and torque bolts 78 ft/lbs. (Figure 2)

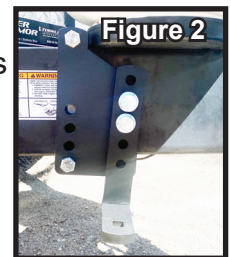

## WARNING

We recommend that this product be installed by an authorized Blue Ox® Professional Installer. Improper installation and/or operation can create a hazard which can cause serious injury, property damage or death. Improper installation and/or operation will void the warranty.

# Operation

## Hooking Up

1. Park the towing vehicle and trailer in a straight line on firm, level ground.
2. Install the hitch head/receiver mount assembly into the towing vehicle receiver tube and secure with the 5/8" x 3" pin and clip.
3. Couple the trailer to the hitch head.
4. Install both spring bars into the hitch head per installation instructions.
5. Confirm that both L brackets are secure against trailer frame.

**Note:** Before each tow, confirm that all brackets are tightened to specified torque specs.

6. Support the trailer tongue weight with the trailer jack to allow for easier hook-up. Place spring bar into dip on lift tool. Then place hook end into the square hole in L bracket. Raise lift tool upward until spring bar securely snaps into place. Place bar locking pin into square hole on L bracket and secure with hair pin. Do this on both sides of the trailer.

## Unhooking

1. Park the towing vehicle and trailer in a straight line on firm, level ground.
2. Support the trailer tongue weight with the trailer jack to ease the tension on the spring bar and allow for easier unhooking. Remove locking pin from L bracket. Place lift tool between spring bar and frame and push inward on top of tool, removing spring bar from L bracket. Do this on both sides of the trailer.



Caution must be used when unhooking due to the potential of injury cause by tension on the spring bars. Hold lift tool firmly as you release the spring bar form the L bracket. Apply pressure to the top of the lift tool in a slow and steady manner.

3. Disconnect the spring bars from hitch head one of two ways. First, lift up slightly on the bar and pull gently outward on the retaining pin on the hitch head. The bar should drop free of the hitch head. Second, rotate the bar away from the trailer and perpendicular to the tow vehicle. Push bar down to remove.
4. Unhook the trailer coupler from the hitch head.
5. Remove the hitch pin and clip from the hitch receiver.
6. Remove the hitch head/receiver mount assembly from the receiver tube.



## WARNING

DO NOT exceed the vehicle manufacturer's specification for trailer gross vehicle weight or tongue weight as this may cause a serious accident and/or injury while towing. Also, be aware that some receiver hitch manufacturers have different weight capacity ratings depending on the use of a weight distribution hitch or not.



## Troubleshooting

**Issue:** After coupling the trailer to the hitch head, the tow vehicle squats and the front of the trailer dips.

**Resolution:** Verify that the ball height and coupler height are matched.

**Issue:** After coupling the trailer to the hitch head, the tow vehicle is level but the front of the trailer dips.

**Resolution:** Adjust the hitch mount receiver higher. Each adjustment up or down equals 1-1/2".

**Issue:** Set-up is over or under adjusted after coupling the trailer to the hitch head, installing, and hooking up hitch.

**Resolution:** Adjust the number of washers on the head tilt pin. Add more washers when close to the maximum tongue weight and fewer washers when close to minimum tongue weight.

**Resolution:** If the maximum or minimum number of washers has been reached and the hitch is still over or under adjusted raise or lower the L bracket to properly adjust set-up.

**Issue:** There is excessive sway.

**Resolution:** Excessive sway may indicate that the trailer is improperly loaded. As a guideline, the tongue weight should be 10-15 percent of gross trailer weight. If it is not, redistribute the weight accordingly. If you encounter continuous sway or swaying that does not dissipate quickly, adjust the load.

**Resolution:** For all truck models with factory sway control, it is suggested that the sway control be disabled for the best performance of the Blue Ox® 2-Point WD Hitch.

**Issue:** The ride is excessively rough.

**Resolution:** Verify that the spring bars are properly rated for your tongue weight.

**Issue:** Experiencing excessive tow vehicle movement.

**Resolution:** Recommend that the tow vehicle tires are inflated to 90% of max inflation state on tire side wall.

## RECEIVER HEIGHTS

### Drop Position

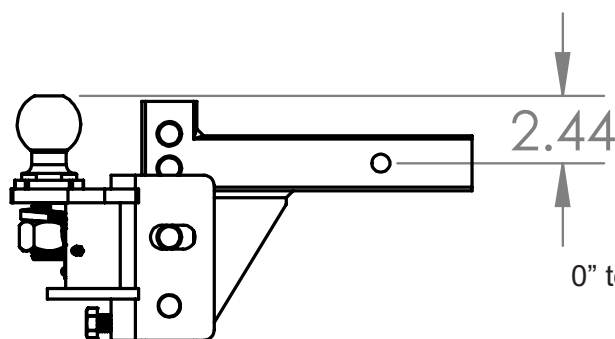

### Rise Position

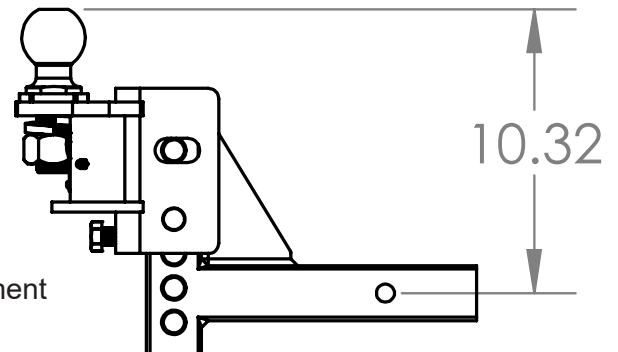



## Replacement Kits

BXW4043	Kit, Spring Bar Lift Tool
BXW4072	Kit, L Bracket Plates
BXW4073	Kit, L Bracket w/ Mount, Single
BXW4074	Kit, L Brackets w/ Mount, Pair
BXW4069	Kit, Long L Bracket Plates
BXW4070	Kit, Long L Bracket w/ Mount, Single
BXW4071	Kit, Long L Brackets w/ Mounts, Pair
BXW4047	Kit, Pins
BXW4068	Kit, 1/2" Retaining Keys
BXW4065	Kit, Hardware
BXW4067	Kit, Hitch Head
BXW4051	Kit, 2" x 7.5K Rate Chrome Plated Hitch Ball
BXW4049	Kit, 2-5/16" x 13K Rated Chrome Plated Hitch Ball

## Spring Bar Kits

BXW4057	Kit, 600 lb. Spring Bars
BXW4058	Kit, 800 lb. Spring Bars
BXW4059	Kit, 1,200 lb. Spring Bars

## Receivers

BXW4066	6 Hole Receiver Mount, 2" Shank
---------	---------------------------------

## Maintenance of your 2-Point WD Hitch

Ensure the round end of the spring bars and hitch head sockets are free from dirt and well lubricated with molybdenum grease. Wipe away any excess grease. If there is excessive wear on these areas, it may indicate that the hitch has been overloaded or not properly lubricated.

Clean the hitch head exterior on a regular basis and remove any stones that may lodge in this area.

To allow for easier use, keep the lift bracket clean and well lubricated.

Annually touch up hitch with a flat black textured spray paint to prevent corrosion.

### Before Each Use:

- Use molybdenum grease to coat the round end of the spring bars.
- Ensure that the coupler and ball are clean. Lightly coat the hitch ball with grease.
- Check that all hardware is properly tightened and the L bracket\ are properly secured.
- Ensure that the hitch receiver is properly installed and the hitch pin and clip are in place.
- Check safety chains and that all electrical hook-ups are in working order.

## CUSTOMER SERVICE COMMITMENT

Blue Ox® is committed to providing you with exceptional customer care throughout your lifetime with our products. Our team is here to assist you with any questions you may have regarding the performance of your product. Simply call (402) 385-3051 and you can speak with our technical service team.

Additionally, please visit our website to see which rallies our Destination America team will be attending. For a nominal fee, our service technician will service your towing system to ensure it's in proper working condition. Also, as a commitment to our customers, should you visit our factory, you can stay at our full service Blue Ox® campground at no charge along with enjoying a factory tour.

Again, thank you for being our customer and for the confidence you have shown in the performance of our products. It is because of customers like you we enjoy the success we have today.

© 2016 Blue Ox  
One Mill Road, Industrial Park  
Pender, Nebraska 68047  
Phone: (402) 385-3051  
Fax: (402) 385-3360  
[www.blueox.com](http://www.blueox.com)

# BLUE OX ORIGINAL PURCHASERS LIMITED LIFETIME WARRANTY

Automatic Equipment Manufacturing Company ("Automatic") warrants to the original (first) retail purchaser that this product, manufactured by Automatic, shall be free from defect in material and workmanship under normal use and service for as long as the original retail purchaser owns the product.

During said period, Automatic will repair or replace any parts that have been returned by the original purchaser, to the factory, transportation prepaid, and in Automatic's sole and absolute opinion found to be defective.

Limitations on Warranty Coverage:

Coverage under this warranty will be valid only if the customer warranty card is returned by the original purchaser within 30 days of purchase.

Coverage under this warranty will be effective only when a copy of the original invoice, showing date and place of purchase, accompanies any claim for warranty. This warranty is NON TRANSFERABLE.

This limited warranty will not cover, in any way or form, any alleged damages caused by incorrect or improper installation, improper use, modification or neglect of product, failure to properly service and maintain, misuse, act of God, accident or failure of the user to follow guidelines contained in the instructional material provided by Automatic.

This warranty does not cover normal wear and tear, paint or rust.

Warrantor assumes no responsibility to the owner for loss of use of product, loss of time, inconvenience or any other damage consequential or otherwise. Including, but not limited to mileage, expense of transporting of product, return shipping expense, mechanics travel time, telephone, road service, towing, and rental during repairs, travel, lodging, loss or damage to personal property or loss of earnings.

**REPAIR OR REPLACEMENT AS SET FORTH IN THIS LIMITED WARRANTY IS THE SOLE EXCLUSIVE REMEDY OF THE PURCHASER. AUTOMATIC SHALL NOT BE LIABLE FOR ANY INCIDENTAL OR CONSEQUENTIAL DAMAGES FOR BREACH OF ANY EXPRESS OR IMPLIED WARRANTY ON THIS PRODUCT. EXCEPT TO THE EXTENT PROHIBITED BY APPLICABLE LAW, ANY IMPLIED WARRANTY OF MERCHANTABILITY OR FITNESS FOR A PARTICULAR PURPOSE ON THIS PRODUCT IS LIMITED IN LENGTH TO THE DURATION OF THIS WARRANTY.**

Please visit <http://blueox.com/warranty/> to register your warranty



**BLUE OX**